

Flash ADC

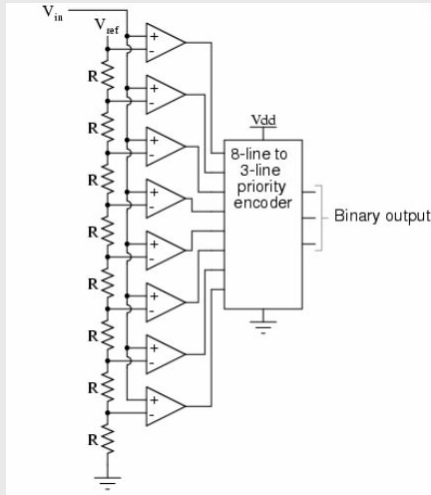

Digital to Analog Conversion



A digital to analog converter (DAC) converts a digital signal to an analog voltage or current output.

Types of DAC

Binary Weighted Resistor

Utilizes a summing op-amp circuit

Weighted resistors are used to distinguish each bit from the most significant to the least significant

Transistors are used to switch between Vref and ground (bit high or low)

Assume Ideal Op-amp

No current into op-amp

Virtual ground at inverting input

$V_{out} = -IR_f$

Pros	Cons
Simple Construction/A	Requires large range of resistors (2000:1 for 12-bit DAC) with necessary high precision for low resistors analysis
Fast Conversion	Requires low switch resistances in transistors
	Can be expensive. Therefore, usually limited to 8-bit resolution.

R-2R Ladder

If the bit is high, the corresponding switch is connected to the inverting input of the op-amp.

If the bit is low, the corresponding switch is connected to ground.

Pros	Cons
------	------

Sigma-Delta ADC

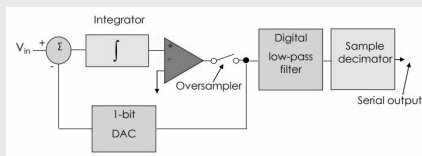

Successive Approximation Register ADC

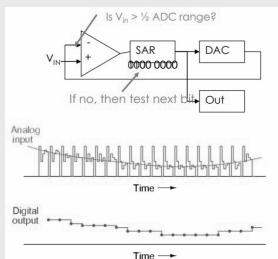

Dual Slope ADC

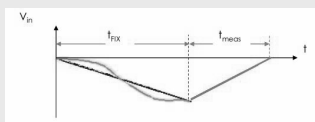

Types of DAC (cont)

Only two resistor values (R and 2R) Lower conversion speed than binary weighted DAC

Does not require high precision resistors

Binary Weigthed Resistor

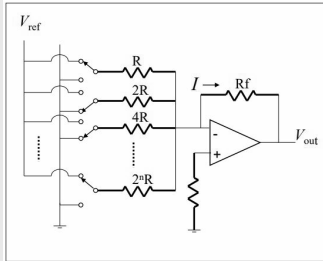

R-2R Ladder

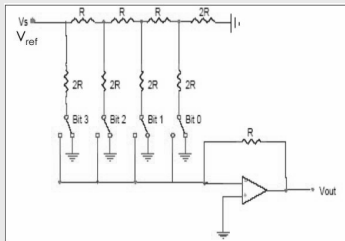

Analog to Digital Conversion

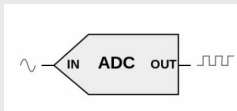

It is an electronic process in which a continuously variable (analog) signal is changed, without altering its essential content, into a multi-level (digital) signal.

Sample and Hold Circuit

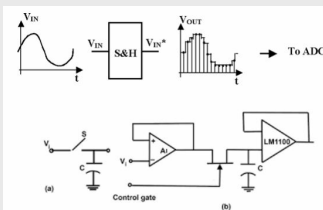

Resolution

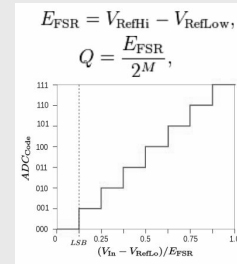

> The resolution of the converter indicates the number of discrete values it can produce over the range of analog values.

> The resolution determines the magnitude of the quantization error and therefore determines the maximum possible average signal to noise ratio for an ideal ADC

ADC Value Calculation

$$\text{ADC Reading} = \text{ADC Input} * \frac{2^N}{V_{ref}}$$

$$V_{ref} = \text{Dynamic Range} = V_{max} - V_{min}$$

$$N = \text{Number of Bits}$$

For an N-bit ADC, the digital representation depends on Number of Bits and Reference values

Example

- > Given a half wave input signal:
 - » $x(t) = A \cos(t)$, $A = 5V$
 - > Full scale measurement rang = 0 to 5 volts
 - > ADC resolution is 8 bits:
 - » $2^8 = 256$ quantization levels (codes)
 - > ADC voltage resolution,
 - » $Q = (5V - 0V) / 256$
 - » $= 5V / 256 \approx 0.0195V$
 - » $Q \approx 19.5mV$.

Common ADC Types

Flash ADC

“parallel A/D”

Uses a series of comparators

Each comparator compares V_{in} to a different reference voltage, starting w/ $V_{ref} = 1/2 I_{sb}$

Pros

Very Fast

Cons

Needs many parts (255 comparators for 8-bit ADC)

Expensive

Large power consumption

Sigma-Delta ADC

Oversampled input signal goes in the integrator

Output of integration is compared to GND

Iterates to produce a serial bitstream

Output is serial bit stream with # of 1's proportional to V_{in}

Pros

High resolution

No precision external components needed

Cons

Slow due to oversampling

Dual-Slope ADC

The sampled signal charges a capacitor for a fixed amount of time

By integrating over time, noise integrates out of the conversion.

Then the ADC discharges the capacitor at a fixed rate while a counter counts the ADC's output bits.

A longer discharge time results in a higher count.

Pros

Input signal is averaged

Greater noise immunity than other ADC types

High accuracy

Cons

Slow

High precision external components required to achieve accuracy

Successive Approximation Register ADC

Sets MSB

Common ADC Types (cont)

Converts MSB to analog using DAC

Compares guess to input

Set bit

Test next bit

Pros

Capable of high speed

Medium accuracy compared to other ADC types

Good tradeoff between speed and cost

Cons

Higher resolution successive approximation ADCs will be slower

Speed limited ~5Msps

Merge columns in Pros and Cons are considered to be in Pros' column

ADC Types Comparison

