

Hardware and Software

Hardware is the physical components of a computer system, whereas **software** is the programs that are run *using* the hardware. Generally, one is useless without the other.

Software Classification

Keyword	Definition	Example(s)
Operating Systems	Software loaded by the computer following the initial boot-up which controls both the hardware and software, including the processor, memory, I/O devices, and security.	Windows 10, macOS
Systems software	Software that controls the operation of hardware in a computer.	
Application software	Programs designed for the user to use to perform a specific task(s).	Internet Explorer, Microsoft Word
Utility Programs	A type of systems software that manages the computer's resources	Defragmentation, file encryption

Truth Tables for Logic Gates

Logic Gate	Truth Table															
AND	<table border="1"> <thead> <tr> <th>x</th> <th>y</th> <th>z</th> </tr> </thead> <tbody> <tr><td>0</td><td>0</td><td>0</td></tr> <tr><td>1</td><td>0</td><td>0</td></tr> <tr><td>0</td><td>1</td><td>0</td></tr> <tr><td>1</td><td>1</td><td>1</td></tr> </tbody> </table>	x	y	z	0	0	0	1	0	0	0	1	0	1	1	1
x	y	z														
0	0	0														
1	0	0														
0	1	0														
1	1	1														

Truth Tables for Logic Gates (cont)

OR	<table border="1"> <thead> <tr> <th>x</th> <th>y</th> <th>z</th> </tr> </thead> <tbody> <tr><td>0</td><td>0</td><td>0</td></tr> <tr><td>1</td><td>0</td><td>1</td></tr> <tr><td>0</td><td>1</td><td>1</td></tr> <tr><td>1</td><td>1</td><td>1</td></tr> </tbody> </table>	x	y	z	0	0	0	1	0	1	0	1	1	1	1	1
x	y	z														
0	0	0														
1	0	1														
0	1	1														
1	1	1														
NOT	<table border="1"> <thead> <tr> <th>x</th> <th>z</th> </tr> </thead> <tbody> <tr><td>1</td><td>0</td></tr> <tr><td>0</td><td>1</td></tr> </tbody> </table>	x	z	1	0	0	1									
x	z															
1	0															
0	1															

Here, 'x' and 'y' are the inputs, while 'z' is the output.

Logic Circuits

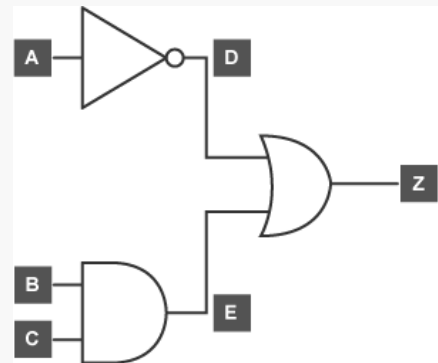

<https://www.bbc.com/education/guides/zc4bb9q/revision/3>

Truth Tables for Logic Circuits

A	B	C	D	E	Z
0	0	0	1	0	1
0	0	1	1	0	1
0	1	0	1	0	1
0	1	1	1	1	1
1	0	0	0	0	0
1	0	1	0	0	0
1	1	0	0	0	0
1	1	1	0	1	1

This is an example of a truth table for the logic circuit above.



Embedded Systems

An **embedded system** is normally built into a larger device. It has a small number of specific functions. An example could be a satnav in a car. **Non-embedded systems**, on the other hand, carry out multiple functions and are not built into anything else

Systems Architecture

Component	Purpose
Central Processing Unit (or CPU)	Processes data and instructions and make decisions. It is composed of many components (e.g. the CU, the ALU).
Control Unit (or CU)	Controls the operation of the ALU, memory and I/O devices; tells them how to respond to instructions it has fetched and decoded.
Arithmetic Logic Unit (or ALU)	Carries out arithmetic and logical operations. Results are stored in a register .
Clock	A crystal that vibrates at high speeds, dictating how many times a second the fetch-decode-execute cycle can be carried out.
Bus	Transports data and instructions around the CPU.
Register	Storage areas in the CPU.
Main Memory	Any form of memory directly accessible by the CPU (excl. cache, registers).

Systems Architecture (cont)

Cache Small, fast memory that is close to the CPU. Stores data that is used frequently.

The AQA specification is only interested in the **Von Neumann Architecture**, which is also called the **Princeton Architecture**. Unlike in **Harvard architecture**, Von Neumann stores data and instructions together.

Von Neumann Architecture

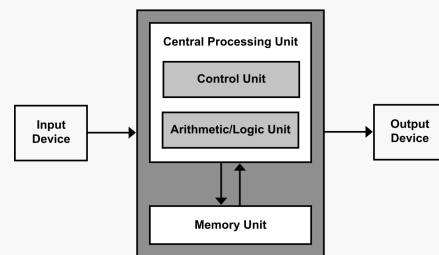

https://en.wikipedia.org/wiki/Von_Neumann_architecture

Fetch-Decode-Execute Cycle

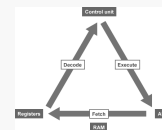

The fetch-decode-execute cycle is a process carried out by the CPU to process an instruction. In the 'fetch' stage, the instruction is loaded into the main memory. The computer then decodes and 'understands' the instruction and executes the instruction. This final stage may include calculation being carried out by the ALU.

Secondary Storage

What is **secondary storage**?

Any storage that isn't under the direct control of the CPU. It stores data and information when the computer is off.

What is **RAM**?

Random access memory. Is volatile, so all data is lost once the power supply is switched off. Stores programs and data currently in use. Can be written to and read from.

Secondary Storage (cont)

What is ROM?

Read only memory. Stores programs needed to boot up the computer. Can only be read from. Non-volatile. Generally smaller in memory capacity.

Types of Storage

Magnetic

Magnetic storage uses magnets to record data on rotating metal plates. The most common example is a hard drive.

Advantages:

1. Large storage capacity
2. Decent read/write access
3. Cheap

Disadvantages:

1. Moving parts result in wear and tear
2. Data can be lost/alterd by magnets

Optical

Optical storage uses a lens and a light beam to read and write data onto a disk (e.g. CD, DVD).

Advantages:

1. Light and portable
2. Cheap
3. Durable
4. Some formats (e.g. CD-R) mean that data cannot be overwritten

Disadvantages:

1. Small storage capacity
2. Specific drive needed to read/write data to/from the disk

Solid State

Solid-state uses flash memories/electrical circuits to store data. It is commonly used in USBs and SD cards.

Advantages:

1. Very quick read/write speed
2. Compact
3. No moving parts
3. Robust

Disadvantages:

1. Expensive
2. Limited number of times that data can be written to

Types of Storage (cont)

Cloud

Data is stored (using normal magnetic/solid state storage) at a remote location and is accessed via the Internet. Popular examples are Google Drive and Dropbox.

Advantages: 1. Can be accessed from anywhere in the world, granting increased flexibility

2. Can be accessed by multiple users at once

3. Users don't need to buy additional hardware

Disadvantages:

1. Requires an Internet connection

2. No control over the data in terms of security

Factors Affecting CPU Performance

Clock Speed Dictates the number of fetch-decode-execute cycles run per second.
(Hz)

Number of Processor Cores Having multiple cores allows a CPU to process multiple instructions simultaneously.

Cache Size Allows the CPU to store more instructions/data that are regularly used, reducing the time taken to process an instruction.

Cache Type L1 cache is faster than L2 and L3 cache.



By [deleted]

cheatography.com/deleted-56036/

Published 13th May, 2018.

Last updated 13th May, 2018.

Page 3 of 3.

Sponsored by [ApolloPad.com](https://apollopad.com)

Everyone has a novel in them. Finish Yours!

<https://apollopad.com>