

### Introduction

GPIO stands for General-Purpose Input/Output. GPIO pins are versatile pins on an MCU that can be configured as either inputs or outputs. They provide a way to interface with the outside world, allowing you to connect and control various external devices, such as sensors, LEDs, displays, and more.

All AVR ports have true Read-Modify-Write functionality when used as general digital I/O ports. This means that the direction of one port pin can be changed without unintentionally changing the direction of any other pin. The same applies when changing drive value (if configured as output) or enabling/disabling of pull-up resistors (if configured as input).

Each output buffer has symmetrical drive characteristics with both high sink and source capability. The pin driver is strong enough to drive LED displays directly.

### I/O Equivalent Schematic

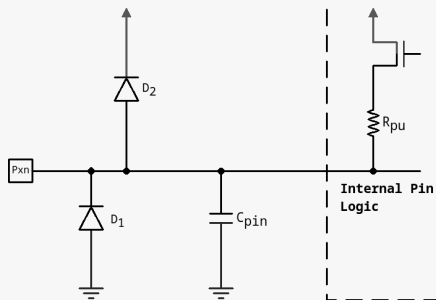

All pins have diodes to protect against undervoltage (D1) and overvoltage (D2).

Each pin features a selectable pull-up resistor (Rpu), ranging from 20k to 50k.

Cpin represents the pin parasitic capacitance; according to the datasheet, it should be less than 10 pF. However, it's important to note that this value is greatly influenced by the PCB layout.



By **bladabuska**

Not published yet.

Last updated 18th October, 2023.

Page 1 of 1.

Sponsored by **Readable.com**

Measure your website readability!

<https://readable.com>